



Manhole Products

**48" Type 2 Precast Catch Basin
WSDOT B-10.20-03**

Square Risers Available

- 2", 3", 4", 6", 12", 24" Solid or w/ Knockouts

Grade Adjustment Rings Available

- 2", 3", 4", 6"

Hole or Knock Out Dimensions

- Maximum hole size is 36 inches
- 8 inches of minimum distance between holes
- 2 inch diameter lifting holes provided
- Cored, cast-in and custom block-out/knock-outs available

Conformity Standards

- ASTM C478 manhole
- ASTM C443 rubber gasket joint
- ASTM D4101 polypropylene steps and ladders
- Washington State APWA / WSDOT Standard

Options Available

- 2' Minimum sump
- Specialized coatings
- Custom hatches
- Kor-N-Seal boots
- 1' thru 10' Polypropylene ladders
- Round offset & center hole flat tops
- Mastic

Base Slab	Flat Top
1,698 LBS	1,667 LBS

Section Specifications

Height	Section
6"	410 LBS
12"	859 LBS
24"	1,735 LBS
36"	2,612 LBS
48"	3,489 LBS
60"	4,365 LBS
72"	5,069 LBS

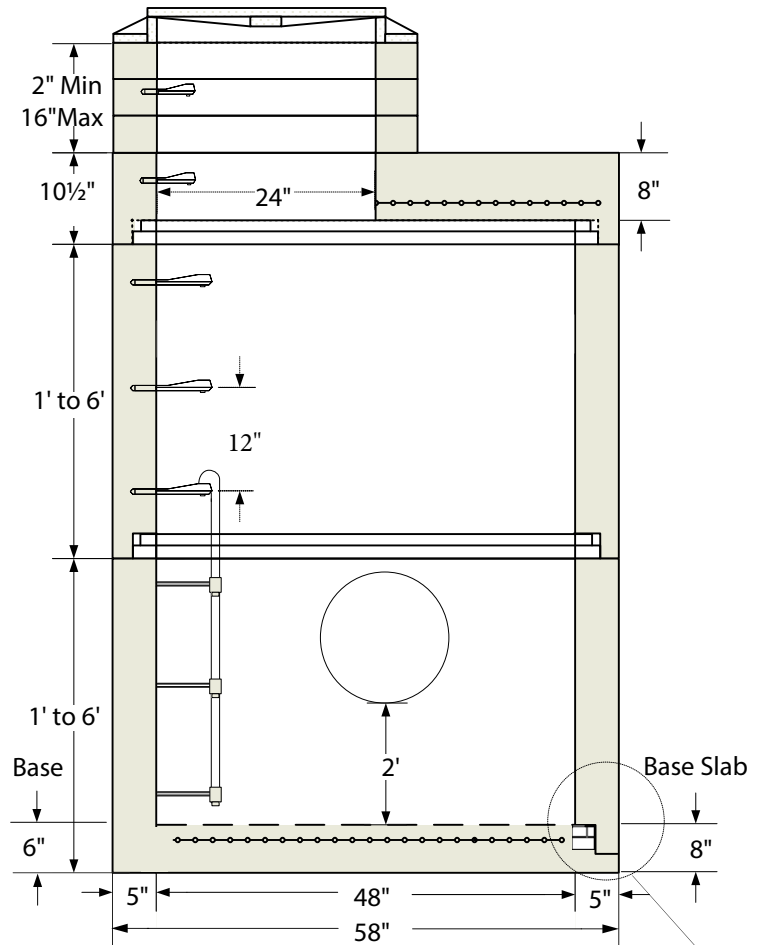

Top Slab Plan View

Gasket Shown Uncompressed

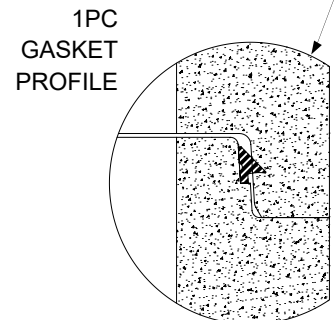
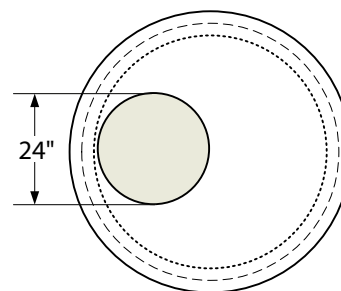
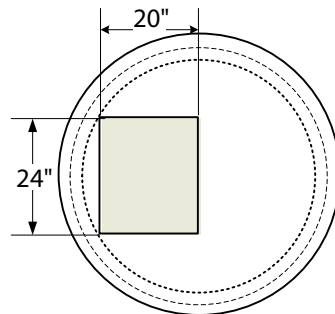

Note: Drawings not to scale

www.shopeconcrete.com

1-800-422-7560 [TOLL FREE]



Shope Concrete, LLC
1618 East Main Avenue
Puyallup, WA 98372-3142

(253) 848-1551
Fax Line 1 (253) 845-0292
Fax Line 2 (253) 864-6172

